

# LAPMASTER®

## MODEL LSP-6

### PRECISION DUAL FACE FLAT LAPPING MACHINE



- The Lapmaster model LSP-6 is a 4-way, planetary, dual face lapping and polishing machine with a sophisticated control system. It can execute complex lapping and polishing routines while producing precise and repeatable results.
- The LSP-6 is able to process extremely thin, fragile components to very tight tolerances repeatably. The machine is initially configured to handle either 66-tooth (140mm/5.5" pitch diameter) or 50-tooth (107mm/4.2" pitch diameter) work carriers, and is easily converted between either configuration.
- Operation is governed by a programmable controller. Custom software prompts the operator for specific operating parameters and stores up to 10 routines for recall as needed. Password protection is available to restrict access to programming or program selection.
- Through a load cell, the controller continually monitors and adjusts the top plate weight to maintain constant pressure on the parts. The LSP-6 has a unique combination of pneumatic pressure controls, frame design, and load control algorithms produce the most accurate and repeatable tolerance results in the industry.
- The five carriers are gear driven for smooth action while lapping thin, fragile parts. In the 66-tooth carrier configuration, the machine holds 5 carriers and can lap or polish most parts down to .076mm/.003" thick. In the 50-tooth carrier configuration, the machine holds 8 carriers and can lap or polish most parts down to .051mm/.002" thick.
- Plates and carrier speeds are varied through AC frequency inverters.
- The machine is built on a box beam frame and the top plate is supported from a frame bridge for stability and durability. The ring gear drops down below the plate to make loading and unloading easier.
- Outward opening, clear plastic guards protect the operator during machine operation. They also keep the slurry confined to the machine, keeping the shop clean.
- Slurry is fed through a variable speed pump. A propeller type agitator guarantees that abrasive stays suspended.
- A part thickness sizing device to automatically shut off the machine, and a water rinse at the end of each run to assist in cleaning are optional.
- Custom lapping and polishing plates are available upon request, as are special electrical services.
- Each machine comes complete with a set of four conditioning gears, a flatness gauge, and a starter kit of abrasive, vehicle and carriers.



## MODEL LSP-6 STANDARD FEATURES

- Programmable process controller.
- Pneumatic top plate weight control with load cell. Accurate to within 1 kg/2.2 lbs Load to 136 kg/300 lbs.
- In-process lap plate flattening.
- Abrasive slurry distribution system with Propeller type agitator, variable speed pump.
- Transparent safety guards with machine access from two sides.
- Retractable ring gear for loading and unloading.
- Anti-vibration mounting and levelling pads.
- Standard electrical service:  
230V or 400V 60 Hz, 3 phase  
110 volt operator controls complies with EN 60 204.
- Durable, polyurathane-coated work table surrounding the lapping/polishing plates.
- Maximum part diameter:  
66-tooth carrier configuration: 127mm (5.0")  
50-tooth carrier configuration: 99mm (3.7").
- Minimum part thickness:  
66-tooth carrier configuration:  
.076mm (.003")  
50-tooth carrier configuration:  
.051mm (.002")

## STANDARD TOOLING

- Two cast iron cross hatched lap plates (66 tooth carriers) 386mm O.D. x 155mm I.D. 15.2" O.D. x 6.1" I.D. (50 tooth carriers) 386mm O.D. x 218mm I.D. 15.2" O.D. x 8.6" I.D.
- Set of four serrated, cast iron dressing gears.
- Starter set of five (66-tooth configuration) or eight (50-tooth configuration) blank, geared work carriers.
- Dial type, precision flatness gauge.
- Starter sample of Lapmaster abrasive or polishing compound.
- Starter sample of Lapmaster lapping vehicle or polishing media.
- Set of Allen keys.
- Operating and maintenance manual.

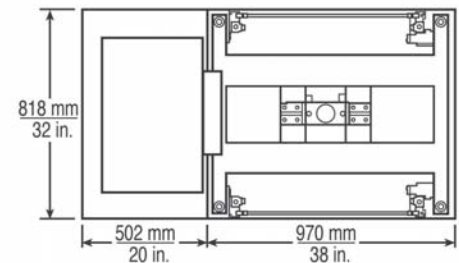
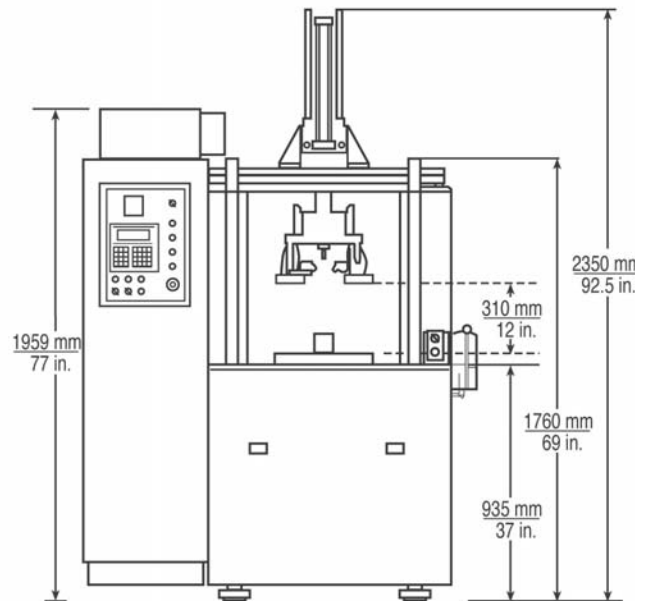

## PACKING SPECIFICATIONS

Export packed in two wooden crates:  
1830mm x 1550mm x 1965mm  
72 in. x 61 in. x 77 in.  
760mm x 760 x 540mm  
30 in. x 30 in. x 21 in.  
Net Weight: 895 kg / 1969 lbs.  
Gross Weight: 1200 kg / 2646 lbs.

## AVAILABLE OPTIONS

- Automatic thickness control.
- Rinse at end of cycle.
- Custom lapping or polishing plate materials and configurations.
- Machines to suit electrical supplies.
- Conversion kit for machine use with both 66-tooth (140mm/5.5" pitch diameter) and 50-tooth carriers (107mm/4.2" pitch diameters).



**Lapmaster International Ltd**

International Lapping and Polishing Machine Systems

Lee Mill Industrial Estate,  
Ivybridge, Devon, PL21 9EN, UK.

Telephone: + 44 (0)1752 893191

Fax: + 44 (0)1752 896355

Email: sales@lapmaster.co.uk

Internet: www.lapmaster.co.uk

Lapmaster has a policy of continued development and the specifications outlined above are subject to change without notice.