

LAPMASTER®

MODEL LSP-20

PRECISION DUAL FACE FLAT LAPPING/POLISHING MACHINE



- The Lapmaster Model LSP-20 is a 4-way, planetary, dual face lapping and polishing machine with a sophisticated control system. It can execute complex lapping and polishing routines while producing precise and repeatable results. The LSP-20 can lap or polish a wide range of materials to very tight specifications.
- The LSP-20 is driven by four, variable speed motors for maximum process control flexibility. All four rotating machine components, the ring gear, sun gear, top plate and bottom plate, are independently controlled. Process down pressure requirements are pneumatically regulated and continuously monitored by a series of three load cells.
- The machine is operated through a graphical, colour interface to a programmable controller. The custom designed software prompts the operator for specific operating parameters and stores up to 25 different lapping and polishing routines containing up to 16 different process steps which can be recalled for later use.
- The five work carriers are pin driven for smooth action while processing fragile parts. Plate and carrier speeds and acceleration are precisely controlled through AC frequency inverters for gentle machine cycle start and end steps. The outer pin drive drops below the plate for the facilitation of machine loading and unloading. Full automation control of the load and unload steps is offered as an option for high production applications.
- The machine is built on a heavy duty, rigid box beam frame. Wetted parts and hardware are made from corrosionresistant materials. The entire head assembly is supported by a 4-station bridge that is raised and lowered through a series of ball screws. The top plate is driven from above to facilitate water cooling both of the lapping and polishing surfaces, if so desired.
- The exposed rotating parts are enclosed by an OSHA and CC compliant reinforced transparent guard that slides out of the way for easy access.
- Slurry is fed through the top plate by variable speed, peristaltic pumping system. A propeller type agitator keeps the abrasive suspended until use.
- A part thickness sizing device to automatically shut off the machine, and a water rinse at the end of each run to assist in cleaning are optional.
- Custom lapping and polishing plates are available upon request, as are special electrical services. Each machine comes complete with a set of four conditioning gears, a flatness gauge and a starter kit of abrasive, vehicle and carriers.



MODEL LSP-20

STANDARD FEATURES

- Programmable process controller with color, graphical user interface.
- Pneumatic top plate control with precise in-process monitoring by load cell.
- Loads to 1818 kgs/4000 lbs
- Process lap plate flattening.
- Four, independently controlled lapping/polishing plate and carrier drives.
- Abrasive slurry distribution system with propeller type agitator, variable speed pump.
- Transparent safety guards with machine access from three sides.
- Retractable ring gear for loading and unloading.
- Corrosion-resistant wetted parts and hardware.
- Anti-vibration mounting and levelling pads.
- Standard electrical service:
3 phase, 380 or 415 volt, 50 Hz
or 3 phase, 460 volt, 60 Hz
- Durable polyurathane-coated work table surrounding the lapping/polishing plates.

STANDARD TOOLING

- Two cast iron cross hatched lap plates or two stainless steel solid polishing plates
Lap: 1369mm O.D. x 480mm I.D.
53.9" O.D. x 18.9" I.D.
Polish: 1389mm O.D. x 460mm I.D.
54.7" O.D. x 18.1" I.D.
- Set of four, serrated, cast iron dressing gears.
- Starter set of five blank, pin type work carriers.
- Dial type, precision flatness gauge.
- Starter sample of Lapmaster abrasive or polishing compound.
- Starter sample of Lapmaster lapping vehicle or polishing media.
- Set of Allen keys.
- Operating and maintenance manual.

AVAILABLE OPTIONS

- Automatic thickness control.
- Rinse at end of cycle.
- Custom lapping or polishing plate materials and configurations.
- Machine to suit electrical supplies.
- Automatic loading and unloading.
- Temperature controlled plates.

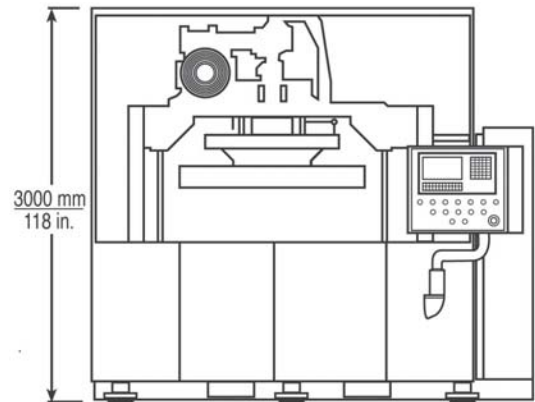
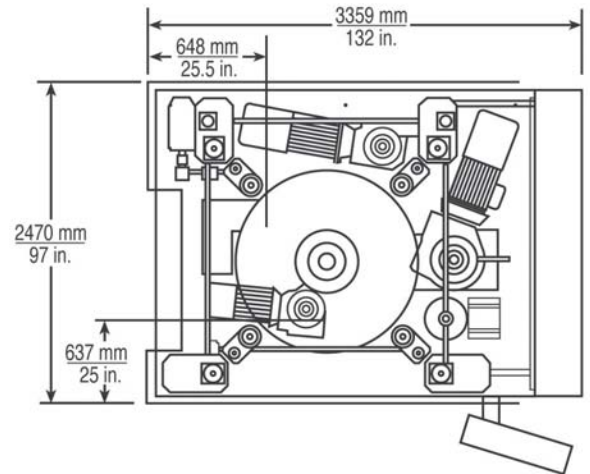

PACKING SPECIFICATIONS

Export packed in three wooden crates:
4100mm x 3308mm x 3250mm
161 in. x 130 in. x 128 in.
720mm x 720mm x 780mm
28 in. x 28 in. x 31 in.
810mm x 660mm x 720mm
32 in. x 26 in. x 28 in.
Net Weight: 14,017 kg / 30,837 lbs
Gross Weight: 17,575 kg / 38,665 lbs.



Lapmaster International Ltd

International Lapping and Polishing Machine Systems

Lee Mill Industrial Estate,
Ivybridge, Devon, PL21 9EN, UK.

Telephone: + 44 (0)1752 893191

Fax: + 44 (0)1752 896355

Email: sales@lapmaster.co.uk

Internet: www.lapmaster.co.uk

Lapmaster has a policy of continued development and the specifications outlined above are subject to change without notice.