



MODEL 48 PRECISION LAPPING MACHINE



- The Lapmaster Model 48 machine features rugged construction, and is equipped with a 48 inch (1219 mm) diameter cast iron lap plate.
- The lap plate is made up of individual segments bolted to a cast iron support plate. These segments are massive enough to provide long life in high production environments, even with multi-shift operation. The surrounding worktable can be simply adjusted as the lap plate wears, so that the sharp edge is never exposed.
- The lap plate drive system uses a separate motor and worm and wheel mechanical reduction gearbox with multi-belt drive, and is mounted in a floor standing base.
- This is a fabricated steel channel framework with removable panels for ease of access during maintenance.
- The drive system incorporates as standard an electronic soft start which will smoothly accelerate the lap plate from standstill to full speed over a controlled time period. This is preset, though it can be adjusted if required, to suit particular process conditions.
- The machine uses a free abrasive slurry, which is supplied from a separate free standing reservoir, equipped with a pump and driven agitator. A diamond slurry dispensing system can also be fitted if required. Outlets are provided to feed each conditioning ring via a track wire, with individual control valves. This system is designed so that a circulatory flow is established. The pump is capable of delivering far more slurry to the outlets than is necessary.
- The excess is returned to the reservoir via a sloping drain tube. This together with the constant agitations provided by the stirrer minimizes the tendency of the abrasive grains to settle out in the vehicle.
- This machine is also available in a pneumatic lift version. See appropriate data sheet.



MODEL 48

STANDARD FEATURES

- Heavy duty floor standing base, with integrally mounted drive motor, and reduction gearbox.
- Heavy duty work table, vertically adjustable.
- Four conditioning rings, with adjustable roller bearing yoke assemblies to maintain lap plate flatness.
- Abrasive slurry distribution system complete with pump, agitator, storage tank, waste container and multiple point feed tubes.
- High torque drive unit consisting of 7.5kW/10hp motor and reduction gear box. Electronic soft-start fitted for Lap plate speed 48 rpm.
- Electrical system wired for 230/460 volt, 60 hertz, 3 phase with operator controls at 110 volts. NEMA Type 12 enclosure, complies with JIC standards.
- Operator control panel with start and stop controls and multiple range, automatic cycle timer.

STANDARD TOOLING

- High density, cast iron serrated lap plate. (consisting of sixteen individual segments)
48" O.D. x 13" I.D. /
1219mm O.D. x 330mm I.D.
- Four high density cast iron serrated conditioning rings. 20" O.D x 17" I.D./ 508mm O.D x 432mm I.D.
- Four workholder blanks.
- Four felt pads.
- Starter sample of Lapmaster abrasive.
- Starter sample of Lapmaster vehicle.
- Set of Allen wrenches.
- Operation and maintenance manual.

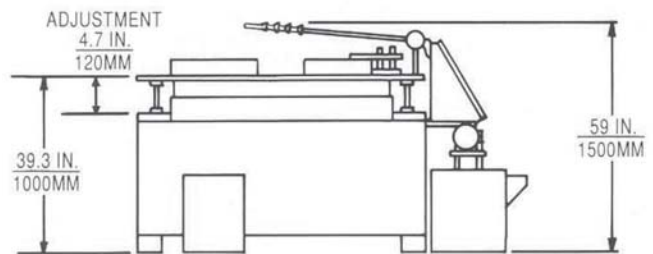
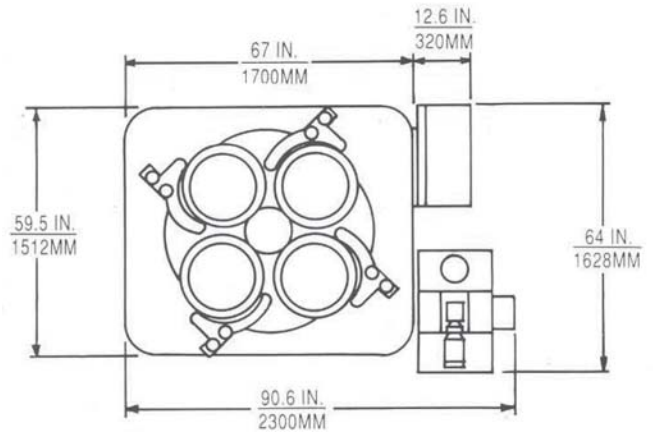

Weight: 7400 lbs/3357 kg
Shipping Weight: 8260 lbs/ 3748 kg

AVAILABLE OPTIONS

- Variable speed lap drive (using frequency inverter)
- Water cooled lap plates.
- Non - standard voltages.
- 3-ring model.
- Enlarged, moveable work table to improve multiple parts handling.



Lapmaster International Ltd

International Lapping and Polishing Machine Systems

Lee Mill Industrial Estate,
Ivybridge, Devon, PL21 9EN, UK.

Telephone: + 44 (0)1752 893191

Fax: + 44 (0)1752 896355

Email: sales@lapmaster.co.uk

Internet: www.lapmaster.co.uk

Lapmaster has a policy of continued development and the specifications outlined above are subject to change without notice.