

# LAPMASTER®

## MODEL 36

### PRECISION OPEN FACE FLAT LAPPING MACHINE



- The Lapmaster Model 36 is the perfect sized machine for engineering workshops where flatness and surface finish are of prime importance over a wide range of component sizes. It is equipped with a 36 inch (914 mm) diameter serrated cast iron lap plate as standard. Other plates can be supplied on request.
- All cast iron used for lap plates and conditioning rings is of the grey type and is artificially aged by heat treatment prior to machining.
- The machine is self-contained and the rigid welded tubular section steel frame supports the reduction gearbox and drive motor and houses the abrasive compound feed tank and the waste tank. Access to these is provided by lift-off panels. The size of machine incorporates as standard a variable speed drive feature which will allow the operator to select the plate rotation speed from 0-70 RPM.
- The machine utilizes a micrograded abrasive such as silicon carbide, boron carbide or aluminum oxide, suspended in a suitable oil or water based vehicle. A diamond slurry dispersion system can also be fitted if required.
- As with all Lapmaster flat lapping machines, provision is made for lateral adjustment of the conditioning ring position, relative to the lap plate track, so that plate flatness can be finely controlled during processing.
- This machine is also available in a pneumatic lift version. See appropriate data sheet.
- The Model 36 can be used to process a wide variety of materials including semiconductors, electro-optics, ceramics, metals and other specialty products.



## MODEL 36

### STANDARD FEATURES

- Heavy duty, tubular steel, floorstanding base with integrally mounted drive motor and gear reducer.
- Heavy Duty work table, vertically adjustable.
- Three conditioning rings, with adjustable roller-bearing yoke assemblies to maintain lap flatness.
- Abrasive slurry distribution system, complete with pump, agitator, storage tank, waste container and multiple point feed tubes.
- High torque drive unit consisting of 5.0hp/4.0kW motor and heavy duty gear reducer. Lap plate speed 58rpm.
- Electrical system wired for 230/460 volt, 60 hertz, 3 phase with operator controls at 110V. NEMA Type 12 enclosure, complies with JIC standards.
- Operator control panel with start and stop controls and multiple range automatic cycle timer.

### STANDARD TOOLING

- High density, cast iron serrated lapping plate. 36" O.D. x 6.75" I.D./914mm O.D. x 172mm I.D.
- Three high density cast iron serrated conditioning rings. 16.5" O.D. x 14.5" I.D./419mm O.D. x 368mm I.D.
- Three high density cast iron pressure plates.
- Three work holder blanks.
- Three sponge rubber pads.
- Starter sample of Lapmaster Abrasive.
- Starter sample of Lapmaster Vehicle.
- Lap plate lifting tool.
- Set of Allen wrenches.
- Operation and Maintenance Manual.

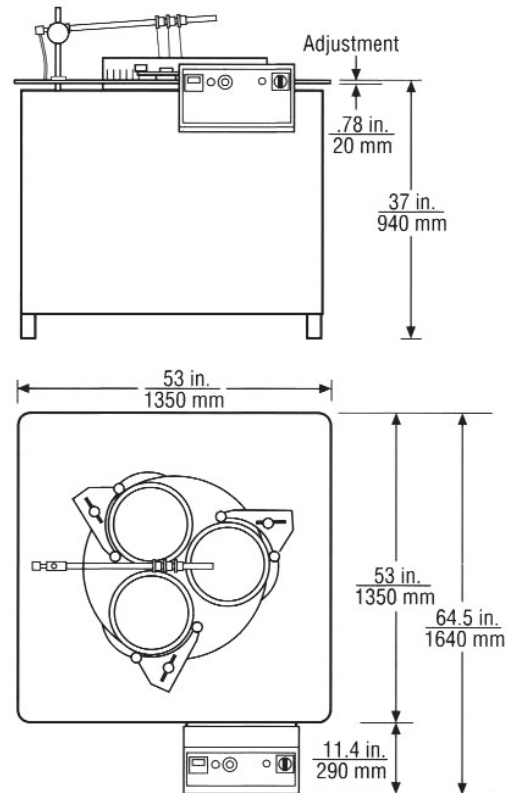

Weight: 2250 lbs / 1020 kg  
Shipping Weight: 2550 lbs / 1156 kg

### AVAILABLE OPTIONS

- 4 ring model.
- Water cooled lap plates.
- Non-standard voltages.
- Custom machines and tooling.
- Enlarged, moveable work table to improve multiple parts handling.



Lapmaster International Ltd

International Lapping and Polishing Machine Systems

Lee Mill Industrial Estate,

Ivybridge, Devon, PL21 9EN, UK.

Telephone: + 44 (0)1752 893191

Fax: + 44 (0)1752 896355

Email: sales@lapmaster.co.uk

Internet: www.lapmaster.co.uk

Lapmaster has a policy of continued development and the specifications outlined above are subject to change without notice.