



MODEL 20

PRECISION OPEN FACE FLAT LAPPING MACHINE



- The Lapmaster Model 20 is a bench-mounted unit with a heavy duty carbon steel weldment base.
- The machine is of the “ring lapper” or “planetary-lapper” configuration, enabling high standards of flatness and surface finish to be routinely achieved.
- The Model 20 is derived from the popular Model 12 and 15 machines but features a steel weldment base instead of cast aluminum. A scaled-up lapping plate, conditioning rings and convenient “wrap-around” worktable combine to form a unique package.
- The Model 20 is the largest bench-mounted machine in the USA offered by any company.
- In-process lap plate flatness control is provided for by three conditioning rings, which locate in yoke/roller bearing assemblies. Work pieces are located within carriers or appropriate fixtures which run within the rings.
- Large parts of cylindrical shape can be substituted for the rings.
- The Model 20 is ideally suited for lapping low or high production quantities. In-shop lapping reduces costs of component processing and equipment maintenance programs. Worn parts are reconditioned and salvaged, thus eliminating scrap. Valve bodies, discs, gears, vanes, valveplates and shaft seals are a few of the components benefiting from the lapping process.
- The Model 20 is equally at home in the laboratory, where it can be used to process a wide variety of materials including semiconductors, electro-optics, ceramics and others. These results can then be applied to a production situation.
- This machine is also available in a pneumatic lift version. See appropriate data sheet.



MODEL 20

STANDARD FEATURES

- Heavy duty steel weldment base.
- Wrap-around worktable facilitates parts handling.
- Three conditioning rings with roller yoke and bearing assemblies to facilitate in-process plate flatness control.
- Abrasive feed system designed for water or oil based lapping slurries, consisting of a 1/15hp/0.05 kW pump, tank and three outlet system with individual variable flow control. This permits uniform lapping rates at each work station.
- High torque drive unit consisting of 1hp/0.75 kW motor and heavy duty, sealed maintenance - free gear reducer. Lap plate speed 70 rpm.
- Electrical system suitable for 220 or 380 or 415V 3ph 50Hz (please state choice) and complies with EN 60204 (other supplies can be catered for on request)
- Removable waste container.

STANDARD TOOLING

- High density, cast iron radially serrated lap plate 20" O.D.x 5" I.D./508mm O.D.x 127mm I.D.
- Three high density, cast iron serrated conditioning rings 9" O.D.x 7 1/2" I.D./ 229mm O.D.x 191mm I.D.
- Three high density, cast iron pressure plates with lifting eyebolts 7 7/16" dia.x 1 1/2" thick/ 189mm dia.x 38mm thick.
- 20"/508mm hardened straight edge.
- Lap plate lifting tool. Standard Tooling.
- Three PVC workholder discs 7 7/16" dia.x 1/8" thick/ 189mm dia.x 3.2mm thick.
- Three felt pads 7 7/16" dia.x 1/2" thick/ 189mm dia.x 13mm thick.
- Starter sample of Lapmaster abrasive.
Starter sample of Lapmaster vehicle.
Operation and Maintenance Manual.
Allen wrench.

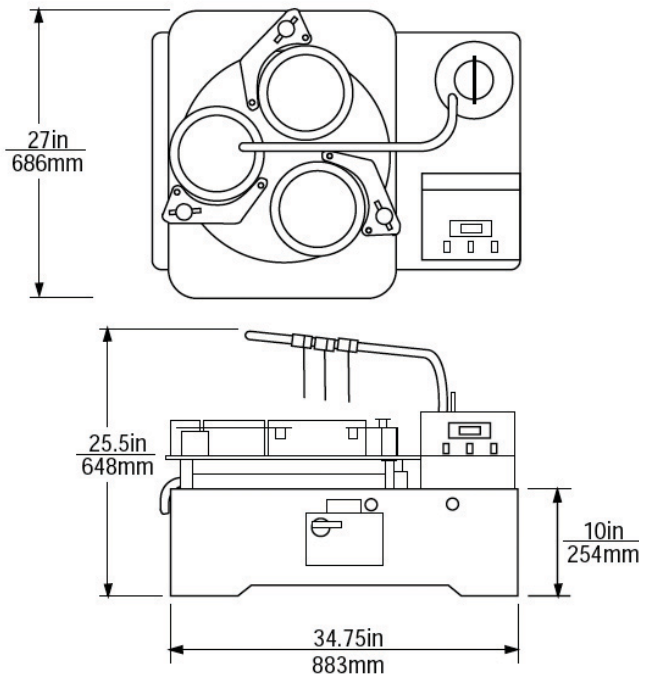

Weight: 435 lbs/196 kg
Shipping Weight: 750 lbs/388 kg

AVAILABLE OPTIONS

- Soft-start (to cushion start-up).
- Electronic variable speed drive (0-70 RPM).
- Diamond slurry dispensing systems.
- Various lapping/polishing plates.
- Non - standard voltages.
- Custom machines and tooling.



Lapmaster International Ltd

International Lapping and Polishing Machine Systems

Lee Mill Industrial Estate,
Ivybridge, Devon, PL21 9EN, UK.

Telephone: + 44 (0)1752 893191

Fax: + 44 (0)1752 896355

Email: sales@lapmaster.co.uk

Internet: www.lapmaster.co.uk

Lapmaster has a policy of continued development and the specifications outlined above are subject to change without notice.